

MARINE FAN COILS INSTALLATION MANUAL



MARINE CHILLED WATER FAN COILS

INSTALLATION MANUAL



- Models :**
- CFPG05
 - CFPG09
 - CFPG12
 - CFPG16
 - CFPG24

CONTENTS

INTRODUCTION	3
--------------	---

INSTALLATION

SAFETY PRECAUTIONS	4
--------------------	---

TECHNICAL PARAMETERS	5
----------------------	---

INSTALLATION OVERVIEW	6
-----------------------	---

INSTALLATION CHECKLIST AND FINAL INSPECTION	7
---	---

OPERATION CONTROLS AND DISPLAY REMOTE	8
---------------------------------------	---

TROUBLING SHOOTINGS	9
---------------------	---

WIRING DIAGRAM	10
----------------	----

INTRODUCTION

Thank you for purchasing our marine chilled water fan coil units, CFPG series units can be used in conjunction with chilled water air-conditioning systems. Standard capacity of the coil is from 5,000 to 36,000 Btu/h. CFPG series of landing fan coils can be installed in cabin or other hermetic space, it is designed for large pleasure yachts and commercial vessels with incorporating the following features:

- 1.** Compact design; large coil shroud volume for optimum performance.
- 2.** High-efficiency internal-motor blower
- 3.** Integrated 3-way bypass valve with easy-change power head.
- 4.** SUS304 Stainless steel drain pan
- 5.** Rotatable blowers.
- 6.** Remote electrical junction box.
- 7.** Water pressure test ports for troubleshooting.
- 8.** Allowance for connecting variable fan speed drives.

This manual provides proper installation information on the chilled water fan coil unit. Improper installation procedures can result in unsatisfactory performance and/or premature failure of these chiller units. Before proceeding please read this manual completely.

In the interest of product improvement, The specifications and design are subject to change without prior notice.

SAFETY PRECAUTIONS

Installation and servicing of this system can be hazardous due to system pressure, moving parts, heat, and electrical components. Only trained and certified service personnel should install, repair, or service equipment. When working on this equipment, always observe precautions described in the literature, tags, and labels attached to the unit. Follow all safety codes. Wear safety glasses and work gloves and place a fire extinguisher close to the work area. Do not work alone.

 **WARNING**

Never install your marine fan coil units in the bilge or engine room areas. Ensure that the selected location is sealed from direct access to bilge and/or engine room vapors.

Do not terminate condensate drain line within 4 feet (1.2 m) of any outlet of engine or generator exhaust systems, nor in a compartment housing an engine or generator, nor in a bilge, unless the drain is connected properly to a sealed condensate or shower sump pump.

Failure to comply may allow bilge or engine room vapors to mix with the marine fan coil's return air and contaminate living areas which may result in injury or death.

 **WARNING**

Electrical shock hazard. Disconnect voltage at main panel or power source before opening any cover.

 **WARNING**

To minimize the hazard of electrical shock and personal injury, chillers, air handlers, and all electrically powered equipment must be effectively grounded. Refer to installation guidelines for further information.

TECHNICAL PARAMETERS

Model No.		AH05	AH09	AH12	AH16	AH24
Cooling Capacity	BTU/h	5000	9000	12000	16000	24000
Elec.Heat	KW	1	2	2	3	3
Air flow	m3/h	300	480	600	800	1000
Power source		230V 50/60Hz				
Input power	W	55	100	150	200	220
Operating current	A	0.3	0.6	0.8	0.9	1.1
Seawater Pipe Size		1/2"	1/2"	1/2"	1/2"	1/2"
Drain Connection Size		DN15	DN15	DN15	DN20	DN20
Water flow	gpm	1.4	2.5	3	4.1	6.2
Dimension (mm)	Width	380	440	440	500	560
	Depth	277	318	318	346	373
	Height	261	310	310	355	430
Net Weight		8.2	10.5	11,6	15.5	21.5

OUTLINE DRAWING

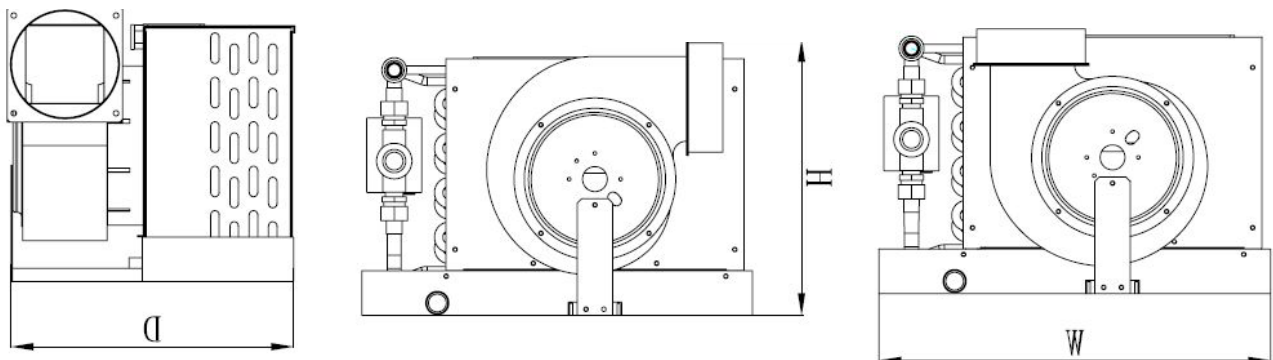

Installation · (FIGURE 1. Installation overview)

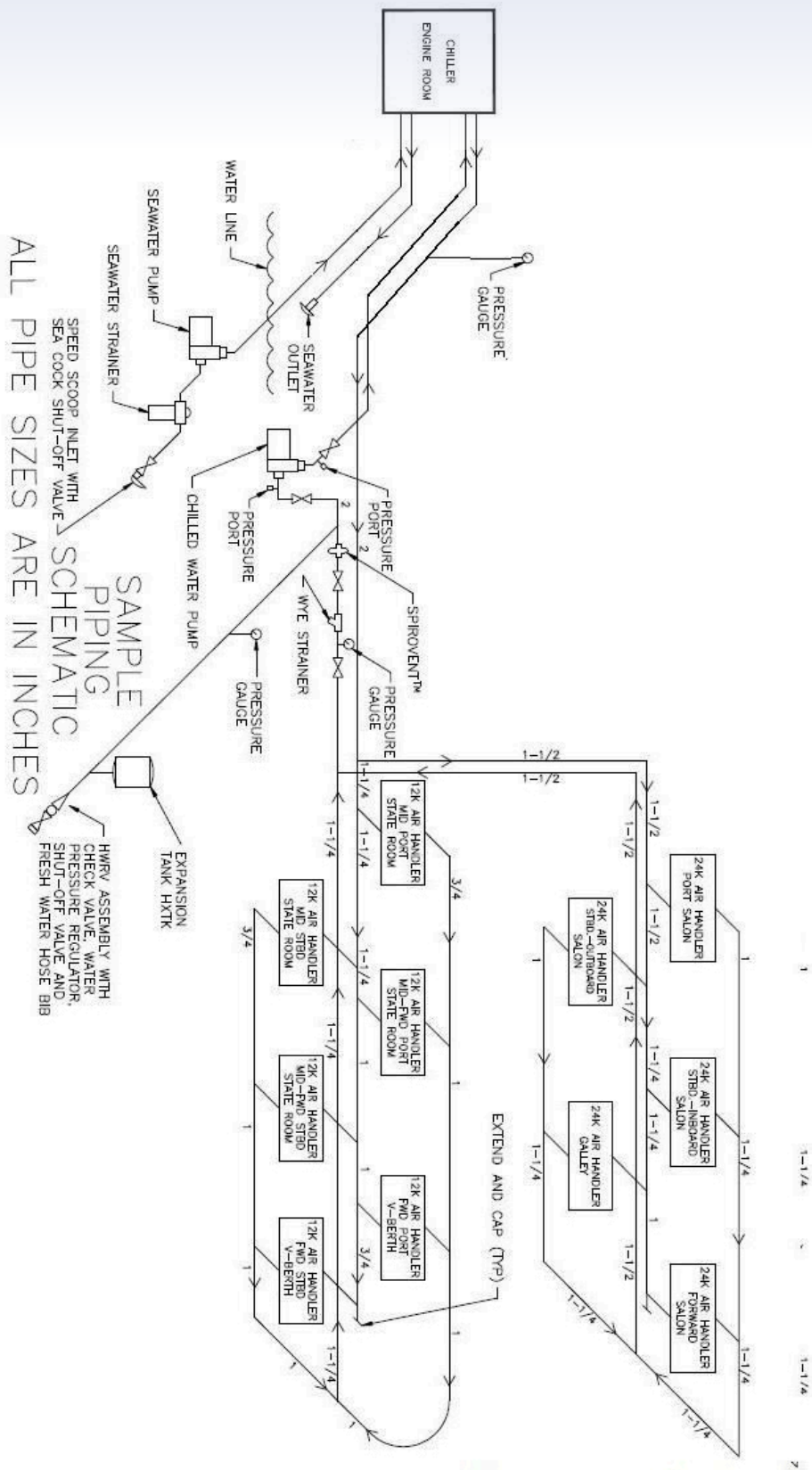

INSTALLATION MANUAL

Check the marine fan coil units

- A.** Check if any damage of the appearance, inside pipes when in transporting and handling.
- B.** Check if the fan motor is rotating normally.

Check the piping system

- A.** Check if the system piping, valves are installed correctly.
- B.** Check if the ducts are loosened or not, its insulations and drains are well done.
- C.** Check if the piping is clean, in order to avoid the unit to be damaged.
- D.** Check if all the opening valves of the system are to be opened, all the off valves of the system are to be shut off.

Check the electricity

- A.** Check if the power source is exactly same with the instructions of the rating label and operation manual.
- B.** Check if the electricity and control circuit are correctly connected, well grounded, all the terminals are fastened.

REMARK: The testing must completed by professional person.

OPERATION CONTROLLERS AND DISPLAY PANEL

The buttons on the wire control can switch on and off the unit, increase/decrease the temperature, set the mode, set the timer, and control the fan speed. etc.



ⓘ On / Off
Press and release to toggle between the **On and Off Modes**

M Mode Button
Press to cycle through the modes of operation. Mode sequence selections are **COOL**, **HEAT**, and **FAN**.

🌀 FAN Button
Press to select Automatic or Manual Fan mode, indicated by the AUTO Fan LED indicator being on or off. In Manual Fan Mode, additional presses of the Fan button will adjust fan speed higher, then lower, then back to AUTO. In AUTO Fan, fan speed is controlled by

the microprocessor as a function of the difference between set point and inside temperature.

▲ Up Button
Press and release to display the set point . Press and hold the **UP** button to increase the set point. Set point increases one degree each time the button is pressed.

▼ Down Button
Press and release to display the set point . Press and hold the **DOWN** button to decrease the set point. Set point decreases one degree each time the button is pressed.

TROUBLE-SHOOTINGS

The PCB controller will estimate the each error which happened in the system operation, and do the treatments according to these error types. The trouble shootings and errors go into four types, which are the unit resumed protection, system resumed protection, unit serious fault protection, and system serious fault protection.

ERROR CODES TABLE

Error Code	Error descriptions	Treatments	Remark
1	Sensor error	To be replaced	
15	Communication errors between PCB and display	Check the wires if good or not	

WIRING DIAGRAM

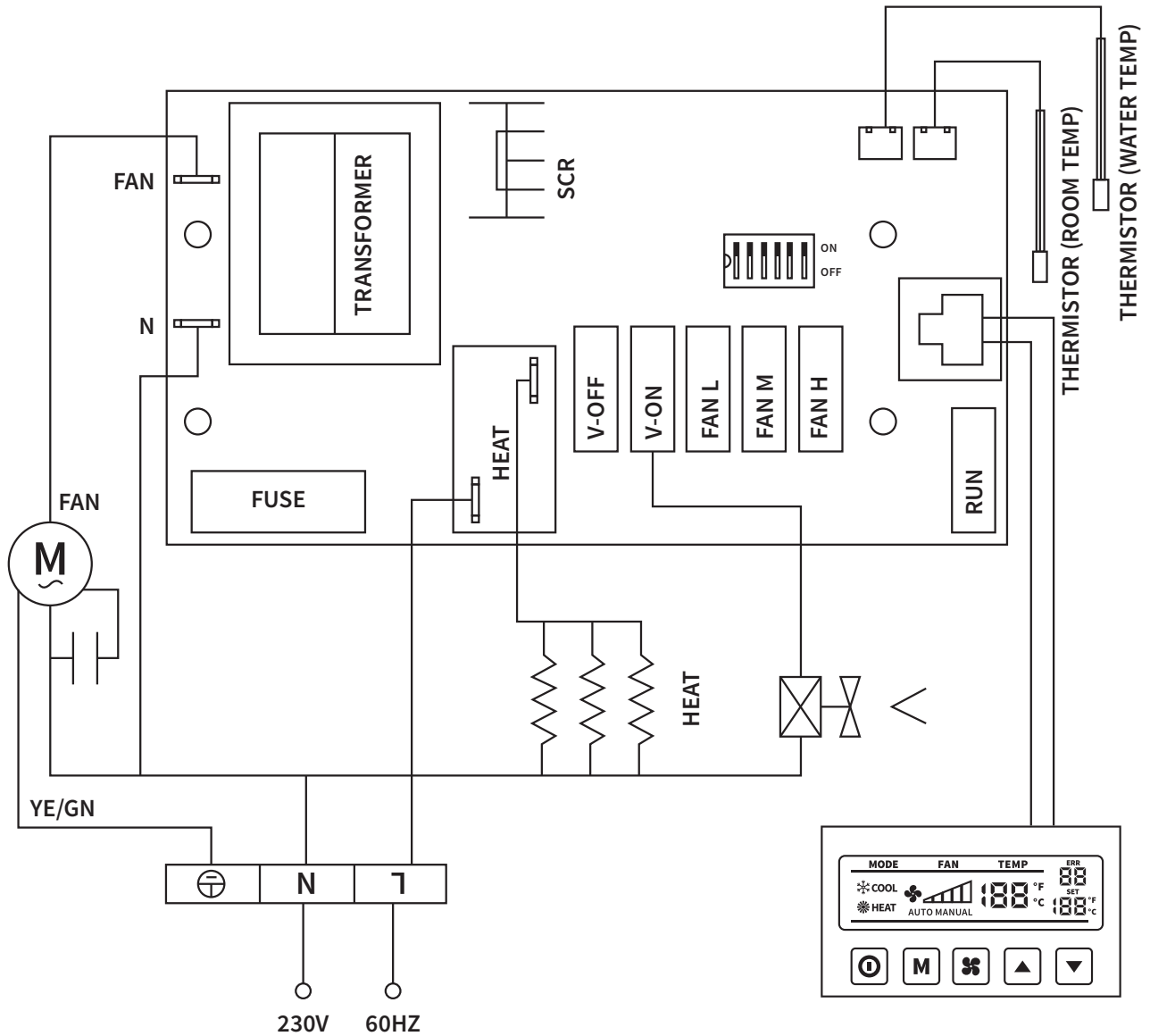



Mabru Power Systems cannot accept responsibility for possible errors in catalogs, brochures and other printed material.

Mabru Power Systems
1105 Old Griffin Rd. | Dania Beach, FL 33004
Tel: 954-467-1770
Email: sales@mabrumarine.com

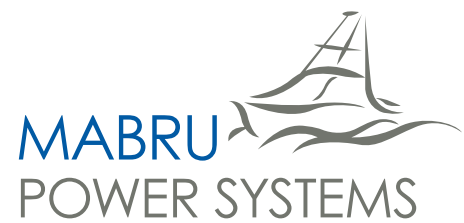

www.mabrumarine.com